



CSC-150

Centralized Busbar Protection IED

Product Guide

BEIJING SIFANG AUTOMATION CO., LTD.

CSC-150 Busbar Protection IED

Version: V2.00

Issued Date: 2022.10

Copyright: Beijing SIFANG Automation Co., Ltd

Note: the company reserves the right to amend the instruction. If equipment does not agree with the instruction at anywhere, please contact our company in time. We will provide you with corresponding service.

 **SIFANG**[®] is registered trademark of Beijing Sifang Automation Co., Ltd.

We reserve all rights to this document, even in the event that a patent is issued and a different commercial proprietary right is registered. Improper use, in particular reproduction and dissemination to third parties, is not permitted.

This document has been carefully checked. If the user nevertheless detects any errors, he is asked to notify us as soon as possible.

The data contained in this manual is intended solely for the product description and is not to be deemed to be a statement of guaranteed properties. In the interests of our customers, we constantly seek to ensure that our products are developed to the latest technological standards as a result; it is possible that there may be some differences between the hardware/software product and this information product.

Manufacturer: Beijing SIFANG Automation Co., Ltd.

Email: support@sf-auto.com

Website: <http://www.sf-auto.com>

Add: No.9, Shangdi 4th Street, Haidian District, Beijing, P.R.C.100085

CSC-150 Busbar Protection IED



CSC-150 is a centralized busbar current differential protection suitable for conventional substations or smart digital substations. It is selective, reliable and high speed protection for busbar faults and breaker failure in medium, high and extra-high voltage substation with various possible busbar configurations, including single bus, single busbar with one-section, double-busbar, double-busbar with one-coupler, double-busbar with one-section and two-coupler, double-busbar with two-section and two-coupler, double-busbar with bypass and breaker-and-a-half.

Powerful capability to cover following applications:

- Up to 26 bays
- Comprehensive functionality including phase segregated low-impedance current differential protection, breaker failure protection, overcurrent protection, earth overcurrent protection and dead zone protection, etc.
- Voltage blocking is an option for the current differential protection and breaker failure protection, which will improve reliability of current differential protection and breaker failure protection
- With CT circuit supervision function, once CT circuit failure is detected, the user can choose CT failure alarm or discrimination zone differential protection blocking
- With the disconnecter position status monitor and memory function, the device will delay the alarm and operate according to the original normal state
- LCD can display real-time main wiring diagram, the status of each breaker and disconnecter, current and power flow, etc.

CSC-150 Busbar Protection IED

- Mixable Binary inputs & output relays / GOOSE inputs or outputs
- Robust hardware with excellent EMC performance and IP54 protection under -40°C to +70°C operating temperature

Application

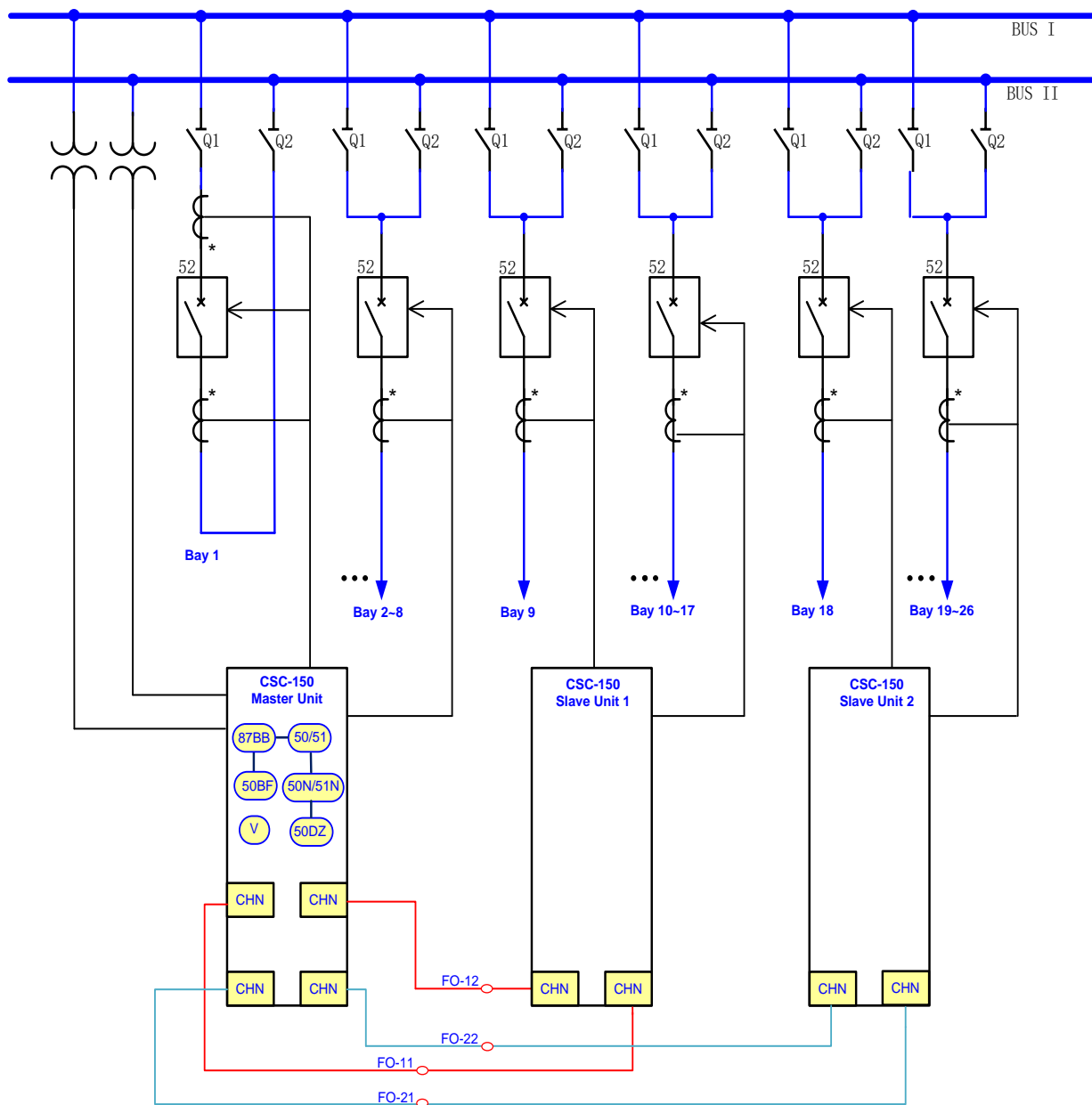

Fault recording

Measurement Monitoring

85-50DZ
85-50BF — PLC Protection interface

COMMUNICATION

- RS-485
- RJ45/FO
- IEC61850
- IEC60870-5-103
- IEC62439-3 PRP

Function

Function	ANSI Code	Qty.	Description
Busbar differential protection	87BB	1	Phase current differential protection with low-impedance principle, check zone and discrimination zone, voltage control element, detection of CT saturation
Single/ three-pole breaker failure protection	50BF	26	For each bay, 2 stages, re-tripping and busbar tripping in sequence, and DTT at 2nd stage
Overcurrent protection	50/51	26	For each bay, 2 stages, definite-time characteristic
Earth fault protection	50N/51N	26	For each bay, 2 stages, definite-time characteristic
Dead zone protection	50DZ	26	For each bay, 1 stage; DTT
CT secondary circuit supervision		26	1 stage for alarm, 1 stage for enable/ disable blocking differential protection
VT secondary circuit supervision	97FF	1	
Disturbance recording			Maximum 5s in 1 recording, up to 32 recordings
Programmable logic			
Self diagnostic			
Time synchronization			IRIG-B, IEEE1588, SNTP, PPS, PPM

Note 1: the number in “Qty.” column is the maximum quantity of function module that can be offered.

Communication

- Support SV, GOOSE service of process layer application in accordance with IEC 61850-8-1, IEC 61850-9-2, IEC 61850-9-2LE
- Support MMS, GOOSE service of station layer and bay layer application in accordance with IEC 61850-8-1
- 3 100Base-TX copper Ethernet ports, or 2 100Base-FX optical Ethernet ports and 1 100Base-TX copper Ethernet port
- 2 RS-485 serial ports, 1 RS-232 print port
- Support all main protocols, include:
 - IEC 61850-8-1
 - DNP 3.0
 - MODBUS
 - IEC 60870-5-103
 - Redundancy protocol IEC 62439-3 PRP
- Support several time synchronizing way, include:
 - IRIG-B modulated electrical/ optical
 - PPS, PPM
 - SNTP
 - IEEE 1588
- Proven technology from thousands of operated digital substations

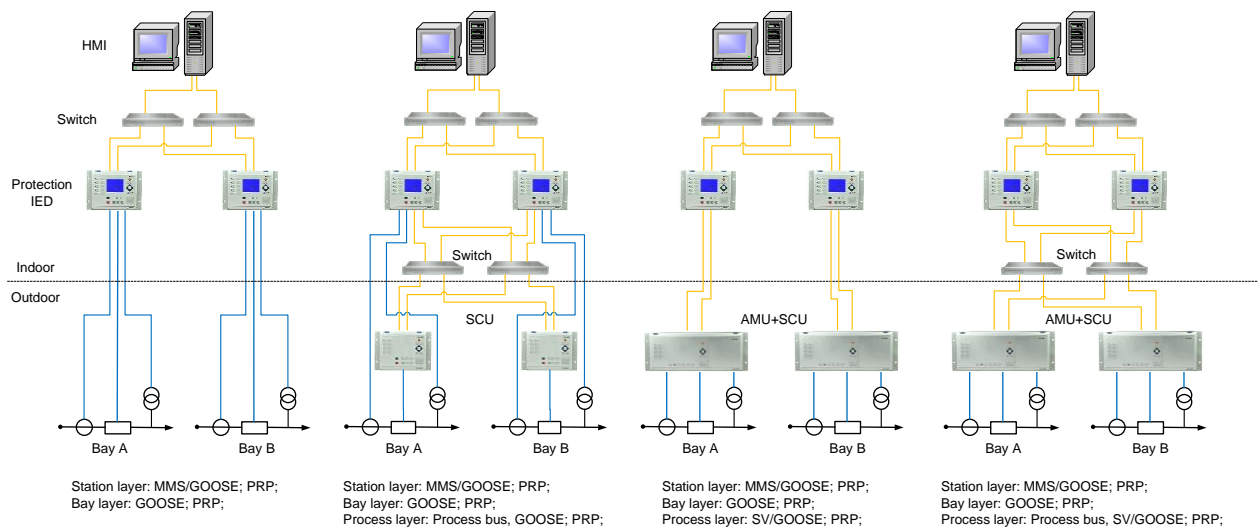

Hardware

- Up to 81 AC current and 6 voltage inputs in one set, 1/5 A compatible
- Up to 145 binary inputs in one set
- Up to 126 binary outputs in one set
- Up to 3 RJ45 Ethernet ports or 2 LC optical Ethernet ports in master unit for SAS
- Up to 2 RS-485 ports and 1 RS-232 print port in master unit;
- 1 IRIG-B / Pulse time synchronization port in master unit;
- 1 front RJ45 for debugging
- 4.7-inch LCD, 320x240 pixels
- 22 programmable LEDs
- Up to 4 customer defined function keys



Front view of the master unit

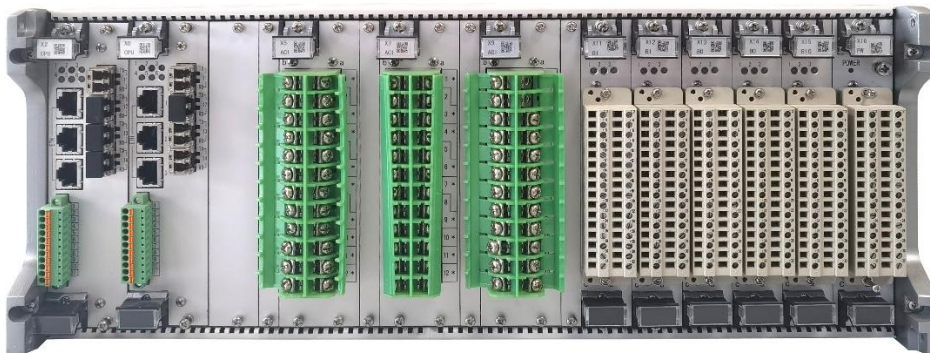

Rear view of the master unit

Hardware



Front view of the slave unit

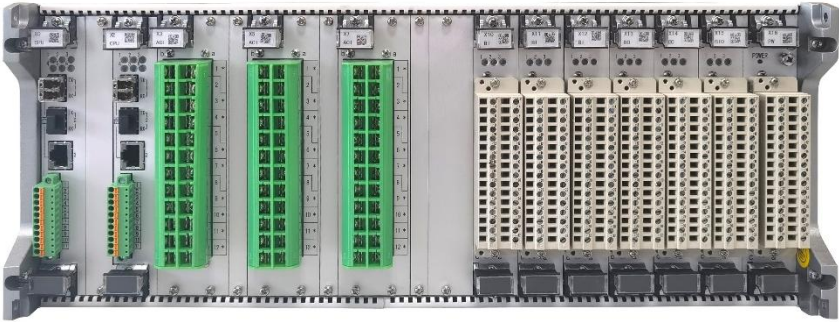

Rear view of the slave unit

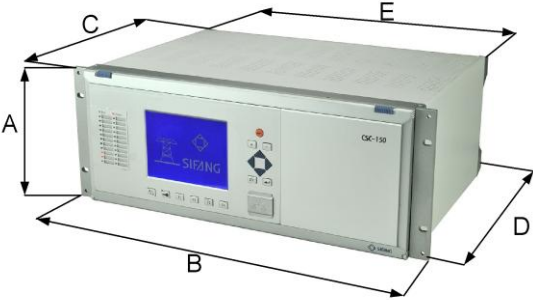

A	177.4
B	482.2
C	322.55
D	343.8
E	446.8
Unit	mm

Dimension of the master and slave unit

Specification

AC current measurement

Item	Data
Rated current I_r IEC 60255-1	1/5 A, settable
Measuring range of protection CT	(0.05 ~ 40) I_r
Measuring range for measurement CT	(0.05 ~ 2) I_r
Burden for CT (per phase) IEC 60255-27	$\leq 0.05VA$ at $I_r=1A$; $\leq 0.25VA$ at $I_r=5A$
Thermal withstand of protection CT (per phase) IEC 60255-27	4 I_r continuously; 30 I_r for 10s 100 I_r for 1s

AC voltage measurement

Item	Data
Rated voltage $V_{r,ph-ph}$ IEC 60255-1	100~120V _{ac} , settable;
Measuring range of VT V_{ph-e}	0.4V ~ 180V
Nominal frequency	50Hz, 60Hz
Burden for VT (per phase) IEC 60255-27	$\leq 0.05VA$, at $V_{r,ph-ph} = 110V$
Thermal withstand of VT (per phase) IEC 60255-27	200V, continuously; 400V for 10s.

Binary inputs

Item	Data
Rated voltage $V_{r,aux}$ IEC60255-1	110/125/220/250 V _{dc} , settable; or 24/48V _{dc} settable;
Operating threshold IEC60255-1	$\geq 70\% V_{r,aux}$, guarantee operating $\leq 55\% V_{r,aux}$, guarantee not operating
Maximum permissible voltage	286V, at $V_{r,aux}=110/125/220/250 V_{dc}$;

IEC60255-1	62V, at $V_{r,aux} = 24/48 V_{dc}$;
Burden for binary input IEC60255-1	Typical $\leq 0.15W$, at $V_{r,aux}=110V_{dc}$ $\leq 0.6W$, at $V_{r,aux}=220V_{dc}$

Output relay

Item	Data
Maximum contact voltage IEC60255-1	250V _{dc} / 400V _{ac}
Current carrying capacity IEC60255-1	5A continuous, 30A, 200ms on, 15s off
Making capacity IEC60255-1	1100W(DC), L/R>40ms 1000VA(AC)
Breaking capacity IEC60255-1	220V(DC), 0.15A, L/R \leq 40ms; 110V(DC), 0.3A, L/R \leq 40ms;
Electrical life IEC60255-1	50,000,000 times at 3Hz
Mechanical endurance IEC60255-1	Load, making ≥ 1000 times Load, breaking ≥ 1000 times
Contact resistance IEC60255-1	30m Ω
Contacts insulation test (AC dielectric voltage) IEC60255-1	1kV _{ac} , 1min

Auxiliary power

Item	Data
Rated voltage $V_{r,aux}$ IEC 60255-1	100V to 250V _{dc/ac} 24/48V _{dc}
Input voltage range IEC60255-1	(0.8~1.2) $V_{r,aux}$
Burden for power supply unit IEC60255-1	$\leq 30W$, at quiescent $\leq 60W$, at maximum load
AC ripple voltage IEC 60255-26	$\leq 15\%$ of the nominal auxiliary voltage

Specification

IEC 61000-4-17

Product safety test

Ethernet communication

Item	Data
Maximum ports number	3
Electrical Ethernet port type	RJ45
Maximum transmission distance of Ethernet cable	100M
2 Optical Ethernet port type	LC
Fiber optic cable type	Multi-mode
Optic wavelength	1310 nm
Maximum transmission distance of optical cable	2km
Transmission rate for IEC61850 or DNP3.0	100Mbit/s

Serial communication

Item	Data
Number	2
Port type	RS-485
Maximum transmission distance	1.0km
Voltage withstand test	500V AC voltage to earth
Transmission rate for IEC60870-5-103 or Modbus	Default setting 9600 bps; Minimum: 1200bps; maximum: 19200bps

Time synchronization

Item	Data
Synchronization mode	SNTP IRIG-B time sync Minute or second Pulse IEEE 1588
IRIG-B signal format	IRIG-B000
IRIG-B Port type	Twisted-pair connection or multi-mode optical fiber
IRIG-B signal voltage level	Differential signal input/ modulated

Item	Data
Over voltage IEC60255-27	Class III
Interference degree IEC60255-27	Degree 2
Insulation type IEC60255-27	Basic insulation
Degree of protection (IP) IEC60255-27 IEC60529	Front: IP54 Top, bottom, left, right: IP52; Rear: IP30
Power frequency insulation voltage withstand test IEC60255-5 EN60255-5 ANSI/IEEE C37.90 GB/T15145-2017 DL/T478-2013	2kV, 50Hz, at rated voltage > 63V, Tested between : Auxiliary power supply port; Current and voltage transformer ports; Input and output ports; Enclosure earth port; 500V, 50Hz, at rated voltage ≤63V, Tested on: Communication ports; Time port; Enclosure earth port;
Impulse voltage IEC60255-27 EN60255-5 ANSI/IEEE C37.90 GB/T15145-2017 DL/T478-2013	5kV(1.2/50μs, 0.5J), at rated voltage>60V, 1kV, at rated voltage≤60V, Tested between : Auxiliary power supply port; Current and voltage transformer ports; Input and output ports; Communication ports; Time port; Enclosure earth port;
Insulation resistance IEC60255-5 IEC60255-27	≥550MΩ, 500V _{dc}

Specification

EN60255-5 ANSI/IEEE C37.90 GB/T15145-2017 DL/T478-2013	
Protective bonding resistance IEC60255-27	≤0.1Ω
Fire withstand/ flammability IEC60255-27	Class V1

EMC test

Item	Data
Pulse immunity test (1MHz) IEC60255-26 IEC61000-4-18 ANSI/IEEE C37.90	Class III 2.5 kV, CM 1.0 kV, DM
Electrostatic discharge immunity test IEC60255-26 IEC61000-4-2	Class IV; ±8kV contact discharge; ±15kV air gap discharge;
Radiated interference radio-frequency electromagnetic field immunity test IEC60255-26 IEC61000-4-3	Class IV; 10 V/m, Frequency sweep: 80 MHz ~1 GHz; 1.4 GHz ~2.7 GHz
Electrical fast transient/burst immunity test IEC60255-26 IEC61000-4-4 ANSI/IEEE C37.90	Class IV; 4kV peak voltage; Tested on: Auxiliary power supply port; Current and voltage transformer ports; Input and output ports; 2kV peak voltage; Tested on: Communication ports;
Surge (impact) immunity test IEC60255-26	Class IV 4.0kV, CM 2.0kV, DM

IEC61000-4-5	
Test for immunity to conducted disturbances, induced by radio-frequency fields IEC60255-22 IEC61000-4-6	Class A 150 Ω , 80% AM (1 kHz) Frequency sweep: 150kHz–80MHz Spot frequencies: 27MHz and 68MHz;
Power frequency immunity test IEC 60255-26 IEC 61000-4-6	Class A 300V, CM; 150V, DM;
Power frequency magnetic field immunity test IEC 60255-26 IEC 61000-4-8	Class V 100 A/m Continuous; 1000 A/m 3s;
Pulse immunity test (100KHz) IEC61000-4-18	Class III 4 kV Tested on: Auxiliary power supply port; Current and voltage transformer ports; Input and output ports; 2 kV Tested on: Communication ports
Damped oscillation magnetic field immunity test IEC61000-4-10	Class V 100A/m
Pulse magnetic field immunity test IEC61000-4-9	Class V 1000A/m
Conducted emission IEC60255-1, CISPR22	Class A; 0.15MHz to 30MHz;
Radiated emission IEC 60255-1, CISPR22	Class A; 30MHz to 1GHz;

Mechanical test

Item	Data
------	------

Specification

Vibration response test IEC 60255-21-1 EN 60255-21-1	Class 1
Vibration endurance test IEC 60255-21-1 EN 60255-21-1	Class 1
Shock response test IEC 60255-21-2 EN 60255-21-2	Class 1
Shock withstand test IEC 60255-21-2 EN 60255-21-2	Class 1
Bump test IEC 60255-21-2	Class 1
Seismic test IEC 60255-21-3	Class 1

Environmental test

Item	Data
Temperature test	-40°C~+70°C, relay energized
Storage test	-40°C~+70°C, relay non-energized
Humidity test	95% r.h. no condensation
Pollution degree	2
Altitude	< 3000m

CE Certification

Item	Data
EMC	EN 60255-26 (Directive 2014/30/EU)
LVD	EN 60255-27 (Directive 2014/35/EU)

Specification

87BB, Busbar differential protection

Item	Data
Differential current threshold	0.2 I _r to 20.00 I _r ≤ ±2.5% setting or ±0.02 I _r
Restraint factor, k	0.3 - 0.99
Operating time	≤ 20ms at 200% setting
Reset time	≤ 50ms
Undervoltage blocking setting	0.0~ 100V
Zero sequence voltage blocking setting	0.0~ 100V
Negative sequence voltage blocking setting	0.0~ 100V

Phase current	0.1 I _r to 20.00 I _r
negative sequence current	≤ ±2.5% setting or ±0.02 I _r
zero sequence current	
Time delay of stage 1	0.00s to 10.00 s, step 0.01s
Time delay of stage 2	≤ ±1% setting or ≤ +40 ms, at 200% setting
Reset ratio	0.95
Reset time	≤ 20ms
Undervoltage blocking setting	0.0~ 100V
Zero sequence voltage blocking setting	0.0~ 100V
Negative sequence voltage blocking setting	0.0~ 100V

50, 51, Overcurrent protection

Item	Data
Definite time characteristic	
Current	0.1 I _r to 20.00 I _r ≤ ±2.5% setting or ±0.02 I _r
Time delay	0.00s to 10.00s, step 0.01s ≤ ±1% setting or ≤ +40ms, at 200% setting

50DZ, Dead zone protection

Item	Data
Current	0.1 I _r to 20.00 I _r ≤ ±2.5% setting or ±0.02 I _r
Time delay	0.02s to 10.00s, step 0.01s ≤ ±1% setting or ≤ +40 ms, at 200% setting
Reset ratio	0.95

50N, 51N, Earth fault protection

Item	Data
Current inputs	Calculated with three phase currents
Definite time characteristic	
Current	0.1 I _r to 20.00 I _r ≤ ±2.5% setting or ±0.02 I _r
Time delay	0.00s to 10.00s, step 0.01s ≤ ±1% setting or ≤ +40ms, at 200% setting

97FF, VT secondary circuit supervision

Item	Data
Phase to earth voltage	5.0V to 20.0V, step 0.01V ≤ ±3% setting or ± 1 V
Phase to phase voltage	10.0V to 30.0V, step 0.01V ≤ ±3% setting or ± 1 V
Recovering phase to phase voltage	40.0V to 120.0V, step 0.01V ≤ ±3% setting or ± 1 V

50BF, Breaker failure protection

Item	Data
------	------