



**CSC-280 Series
Multifunction Protection IED
Product Guide**

Version: V3.01
Issued Date: 2025.11
Copyright owner: Beijing SIFANG Automation Co., Ltd

Note: the company keeps the right to perfect the instruction. If equipment do not agree with the instruction at anywhere, please contact our company in time. We will provide you with corresponding service.

 **SIFANG**® is registered trademark of Beijing SIFANG Automation Co., Ltd.

We reserve all rights to this document, even in the event that a patent is issued and a different commercial proprietary right is registered. Improper use, in particular reproduction and dissemination to third parties, is not permitted.

This document has been carefully checked. If the user nevertheless detects any errors, he is asked to notify us as soon as possible.

The data contained in this manual is intended solely for the IED description and is not to be deemed to be a statement of guaranteed properties. In the interests of our customers, we constantly seek to ensure that our products are developed to the latest technological standards as a result it is possible that there may be some differences between the hardware/software product and this information product.

Manufacturer:
Beijing Sifang Automation Co., Ltd.

Tel: +86 10 62962554, +86 10 62961515 ext. 8998

Fax: +86 10 82783625

Email: sf_sales@sf-auto.com

Website: <http://www.sf-auto.com>

Add: No.9, Shangdi 4th Street, Haidian District, Beijing, P.R.C.100085



Overview

CSC-280 series are compact, reliable multifunction protection IED (Intelligent Electronic Device), which are able to be applied for protection, control and measurement for following applications:

- ◆ Applicable in subtransmission network and distribution network, with solidly earthed (grounded), low-resistance earthed, isolated or compensated neutral point
- ◆ Protection of feeders, capacitors, distribution transformers, bus coupler, motor, etc.

- ◆ Used as backup protection IED for lines, transformers, reactors and motor
- ◆ Providing control and monitoring functions of the circuit breakers, isolator
- ◆ Supporting all functionalities required for automation system

The wide application flexibility and integration of the protection, monitoring and control functions in one device makes the IED an excellent solution for both new installations and retrofitting of the existing stations.

Features

- ◆ Extensive multifunction IED including protection, control and monitoring functions
- ◆ Three pole tripping required in sub-transmission and distribution network
- ◆ A complete protection functions library
- ◆ Bus VT secondary circuit connection/disconnection
- ◆ Independent CB open/close circuit
 - Opening and closing lockout circuit
 - Opening and closing circuit supervision
 - CB status indication
- ◆ CB operating status supervision
- ◆ Self-supervision
- ◆ Complete and massive reports recording, trip reports, alarm reports, startup reports and operation reports. Any kinds of reports can be stored no less than 40 items, and be memorized in case of power disconnection
- ◆ Up to two electric Ethernet ports can be selected to communicate with substation automation system
- ◆ Up to two electric RS-485 port is able to communicate with substation automation system by protocol
- ◆ Support IEC61850, IEC60870-5-103, DNP 3.0 and MODBUS.
- ◆ Time synchronization via network(SNTP), pulse and IRIG-B mode
- ◆ Versatile human-machine interface
- ◆ Multifunctional software tool for setting, monitoring, fault recording analysis, configuration, etc.

Products

Model	Protection IED	Application
CSC-281-EC	Multifunction protection IED	For MV feeder, capacitor, and auxiliary transformer;
CSC-282-EC	Transformer protection IED	For 2 winding transformer;
CSC-283-EC	Motor protection IED	For motor;
CSC-284-EC	Line differential protection IED	For feeder in transmission or distribution
CSC-285-EC	Voltage protection IED	For load shedding, grid disconnection and VT;

Protection functions

Function	ANSI Code	281	282	283	284	285
Line differential protection	87L				■	
Transformer differential protection	87T		■			
Restricted earth fault protection	87REF		□			
Directional overcurrent protection	67	■			■	
Overcurrent protection	50,51	□	□		□	
Directional earth fault protection	67N	■		■	■	
Earth fault protection	50N,51N	□	□		□	
Directional sensitive earth fault protection	67Ns	□			□	
sensitive earth fault protection	50Ns,51Ns	□			□	
Negative-sequence overcurrent protection	46			■		
Undercurrent protection	37			■		
Manual/Automatic switch-onto-fault protection	50SOTF	■			■	
Thermal overload protection	49	■	■	■	■	
Overvoltage protection	27	□		■	□	■
Under voltage protection	59	□		■	□	■
Displacement voltage protection	59N	□		■	□	■
Negative sequence overvoltage protection	47			■		
Auto-reclosing		■			■	
Synchro-check & voltage check	25	□			□	
Overfrequency protection	81O	□		□	□	
Underfrequency protection	81U	□		□	□	
Frequency change of rate protection				□		
Long start protection	48			■		
Motor stall protection				■		

Function

TE time protection				■		
Reverse phase sequence protection	47			■		
Circuit breaker protection	50BF	■			■	
Load shedding by underfrequency	LS-81U					■
Grid disconnection by overfrequency	GD-81O					■
VT secondary circuit supervision	97FF	■		■	■	■
CT secondary circuit supervision						

Control functions

Description
Circuit breaker, isolator and other switching devices control
Opening and closing lockout circuit
Tripping and closing circuit supervision

Monitoring functions

Description
Status of circuit breaker, isolator and other switching device monitoring
Circuit breaker operating status supervision
Auxiliary contacts of circuit breaker supervision
Self-supervision
Disturbance recorder, Max. 5s in 1 recording, up to 32 recordings
Circuit breaker spring status supervision

Station communication

Description
Front communication port
RJ45 Ethernet port

Function

Rear communication port
0-2 isolated electrical RS485 communication ports
1 Ethernet electrical/optical communication ports
1 Time synchronization port
Communication protocols
Ethernet communication: IEC 61850, DNP 3.0; Serial communication: IEC 60870-5-103, MODBUS;

Remote communication for protection

Description
Optical communication ports for protection
2 LC optical communication ports for line differential protection or pilot wire differential protection via CSC-186D communication convertor Note: for CSC-284-EC only.

Hardware

Human-machine Interface (HMI)

The human-machine interface is simple and easy to understand – the whole front plate is divided into zones, each of them with a well-defined functionality:

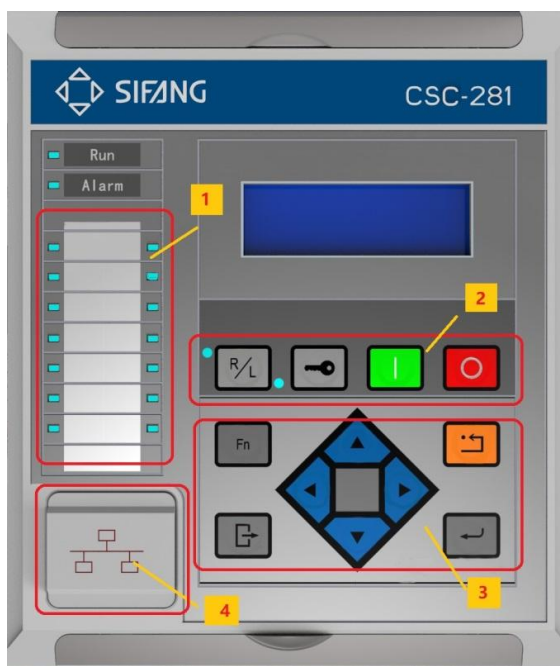

Figure 1 The front plate of IED

- 1 14 configurable LEDs
- 2 Function keys
- 3 Navigation keys
- 4 Ethernet port

Rear view

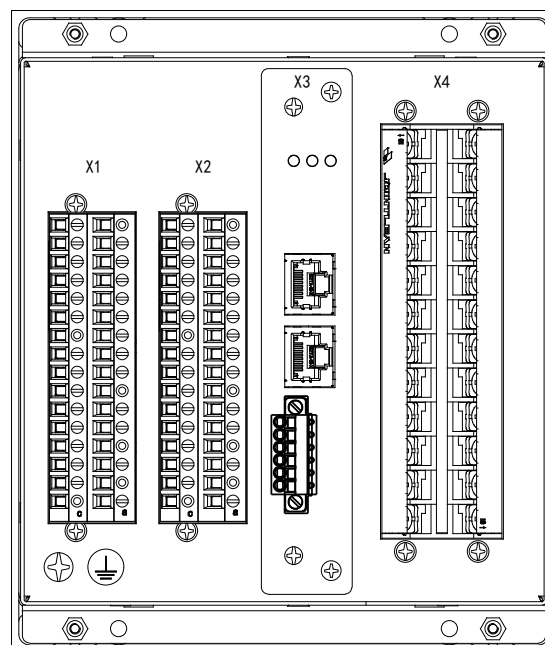

Figure 2 The rear view of IED

Hardware

Transformer Input Module (TIM)

The analogue input module is used to galvanically separate and transform the secondary currents and voltages generated by the instrument transformers.

AC			
	b	a	
1	Ia1A'	Ia1A	CURRENT
2	Ia5A'	Ia5A	
3	Ib1A'	Ib1A	
4	Ib5A'	Ib5A	
5	Ic1A'	Ic1A	
6	Ic5A'	Ic5A	
7	I01A'	I01A	
8	I05A'	I05A	
9	U4'	U4	VOLTAGE
10		Ua	
11	Un	Ub	
12		Uc	

Figure 3 Terminal diagram of transformer input module

Communication module (COM)

The module provides synchronization and communication ports as following.

- 2 isolated electrical/optical fiber Ethernet ports
- 1 RS485 serial communication port
- 1 time synchronization port

The IED is able to meet the demands of different substation automation system and RTU at the same time.

The pulse, IRIG-B or SNTP time synchronization mode can be applied.

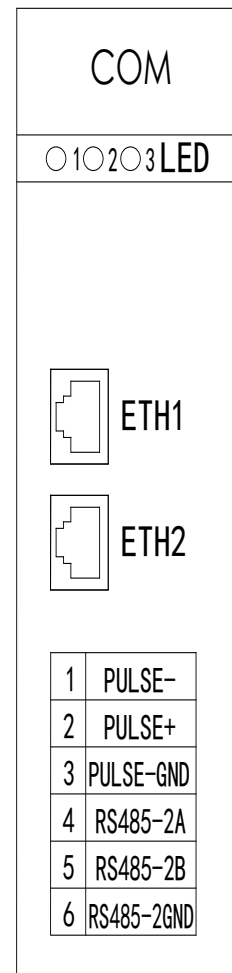

Figure 4 Terminal diagram of communication module

Hardware

Binary input & output module (BIO)

This module provides tripping outputs with tripping circuit supervision and signaling outputs for protection functions and binary inputs as following.

- 1 heavy duty output relays, with tripping circuit supervision
- 4 NO general output relays for tripping, control or signaling
- 1 NO/NC general output relay
- 8 binary inputs
- 1 analog input (optional)
- 2 analog outputs (optional)

DIO		
	c	a
2	P02+	KM2+
4	P02-	K1-2
6	B06 (NO)	
8	B07 (NO)	
10	B08 (NO)	
12	B09 (NO)	
14	B010 (NO)	B010-
16	B010 (NC)	BICOM
18	BI10	BI7
20	BI11	BI8
22	BI12	BI9
24	BI13+	BI13-
26	BI14+	BI14-
28	A11+	A11-
30	A01+	A01-
32	A02+	A02-

Figure 5 Terminal diagram of binary output & input module

Note: The BI14 will be occupied when TCS function is used.

Power Supply Module (PSM)

The power supply module does not provides auxiliary power only, but also outputs, binary inputs and RS485 series communication port, listed as following.

- 1 heavy duty output relays, with tripping circuit supervision
- 4 NO general output relays
- 1 NC internal failure alarm relay
- 6 binary inputs
- 1 RS485 serial communication port

POWER		
	c	a
2	RS485-1A	RS485-1B
4	RS485-1GND	
6	B01 (NO)	
8	B02 (NO)	
10	B03 (NO)	
12	B04 (NC)	
14	B05-fail (NC)	
16	P01+	KM1+
18	P01-	K1-1
20	BI3	BICOM
22	BI4	BI1
24	BI5	BI2
26	BI6+	BI6-
28	PWR+	PWR-
30		
32		

Figure 6 Terminal diagram of power supply module

Note: The BI6 will be occupied when TCS function is used.

Layout and dimension

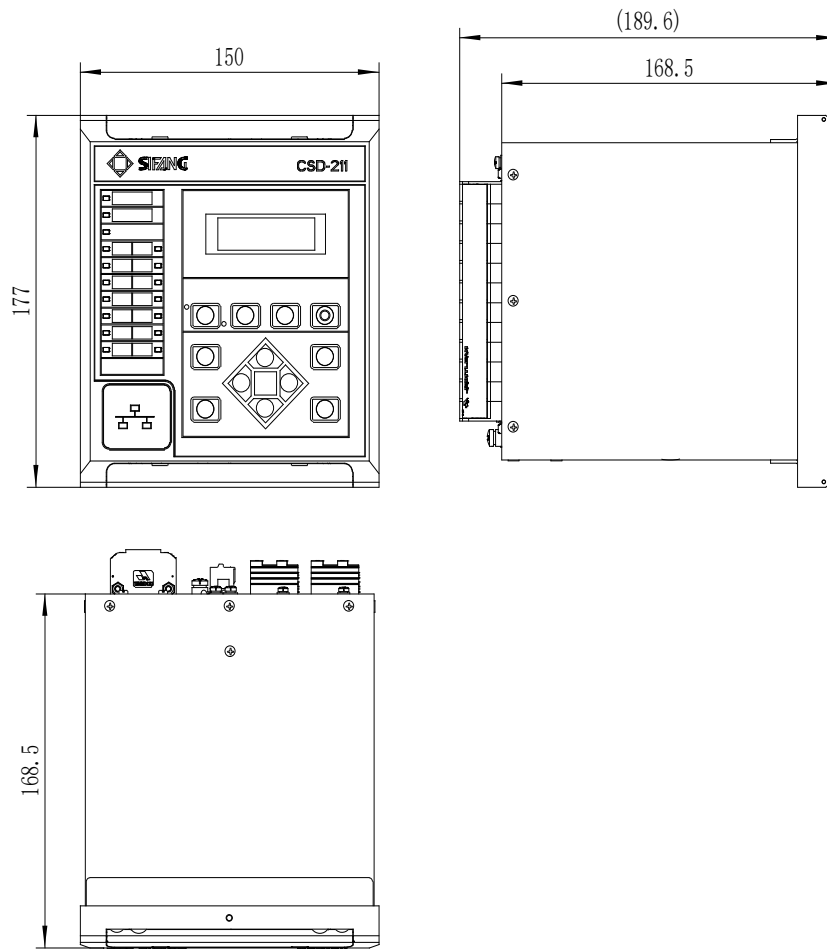

Figure 7 Case of CSC280 series protection IED

Hardware

Typical hardware scheme	CSC-28x-EC-A	CSC-28x-EC-B	CSC-28x-EC-C
AC current inputs	3	3	3
AC normal/sensitive current input	1	1	1
AC voltage inputs	4	4	
Analog inputs	1	1	
Analog outputs	2	2	
Binary inputs	14	6	6
Power outputs with TCS	2	1	1
General outputs (NO)	8	4	4
General outputs (NO/NC)	1		
Device failure alarm (NC)	1	1	1
RS-485 ports	2	2	1
Ethernet ports	2	2	
Time synchronization port	1	1	
Configurable LEDs	14	14	14
Open/Close button	1/1	1/1	1/1

Specification

AC current measurement

Item	Data
Rated current I_r	1A and 5A
Operating range of protection CT	$(0 \sim 100) I_r$
Measuring range of protection CT	$(0.05 \sim 40) I_r$
Reading Accuracy for protection CT	$\pm 1\%$ at $I > I_r$ $\pm 0.5\%$ at $I \leq I_r$
Thermal overload capacity of protection CT IEC60255-27	4 I_r Continuously; 30 I_r for 10s 100 I_r for 1s
Power consumption (per phase)	$\leq 0.15VA$ at $I_n=1A$; $\leq 0.3VA$ at $I_n=5A$
Dynamic thermal overload capacity	250 I_r for 1.5 cycle

AC voltage measurement

Item	Data
Rated voltage $V_{r,ph-ph}$ IEC60255-1	100V ~ 120V, settable;
Measuring range V_{ph-e}	0.1V ~ 180V
Reading accuracy V_{ph-e}	$\pm 1\%$ at $>10\% V_{r,ph-e}$. 0.03V at $\leq 10\% V_{r,ph-e}$
Power consumption IEC60255-27 DL/T478-2013	$\leq 0.05VA/Phase$, at $V_{r,ph-ph} = 110V$
Thermal overload capacity V_{ph-e} IEC60255-27 DL/T478-2013	180V, continuously; 400V for 60s.

Other measurement

Item	Data
Rated frequency	50Hz / 60Hz, settable
Measuring range of frequency	$\pm 10\%$ F_n
Reading accuracy of frequency	$\pm 0.02Hz$

Reading accuracy of angle	$\pm 1^\circ$, at rated AC voltage and AC current
Reading accuracy of power and reactive power	1%, at rated voltage and current

Binary inputs

Item	Data
Rated voltage $V_{r,aux}$ IEC60255-1	110V/125V/220V/250V DC, settable; Or 24V/48V DC settable;
Max. permissible voltage IEC60255-1	300V, at rated 110V/ 125V/ 220V/ 250V DC; 62V, at rated 24V/ 48V;
Operating Threshold IEC60255-1	$\geq 70\%$ $V_{r,aux}$, guarantee operating $\leq 55\%$ $V_{r,aux}$, guarantee not to operating
Pickup time	Approx. 1ms, intrinsic
Dropout time	Approx. 2ms, intrinsic
Power consumption IEC60255-1	$\leq 0.1 W/input$, at $V_{r,aux}=110V$ DC $\leq 0.5 W/input$, at $V_{r,aux}=220V$ DC

Output relay

Item	Data
Rated contact voltage IEC60255-1	24V, 48V, 110V, 220V DC 100V, 220V AC
Maximum contact voltage IEC60255-1	250V AC/DC
Current carrying capacity IEC60255-1	General relay: 5A continuous, 10A, 1s on, 15s off 30A, 200ms on, 15s off Power output relay: 10A continuous, 30A, 200ms on, 15s off
Making capacity IEC60255-1	General relay: 1100W(DC) at $L/R > 40ms$

Specification

	1000VA(AC) Power output relay: 1250W (DC) 2000VA(AC)
Breaking capacity IEC60255-1	General relay: 0.2A, at $V_{r.aux}=220V$, L/R \leq 40ms; 0.4A, at $V_{r.aux}=110V$, L/R \leq 40ms; 1000VA, at $V_{r.AC}$; Power output relay: 0.25A, at $V_{r.aux}=220V$, L/R \leq 40ms; 0.45A, at $V_{r.aux}=110V$, L/R \leq 40ms; 1200VA, at $V_{r.AC}$;
Pick up time IEC60255-1	General relay: \leq 5ms Power output relay: \leq 5ms
Drop off time IEC60255-1	\leq 10ms

Auxiliary power

Item	Data
Rated voltage $V_{r.aux}$ IEC60255-1	100V to 250V DC/AC 24/48V DC
Input voltage range IEC60255-1	\pm 20% $V_{r.aux}$
Static power consumption IEC60255-1	\leq 18W
Maximum load power consumption IEC60255-1	\leq 20W

Ethernet communication

Item	Data
Max. ports number	3
Electrical Ethernet port type	RJ45
Maximum transmission	100M

distance of Ethernet cable	
Optical Ethernet port type	LC
Fiber optic cable type	Multi-mode
Optic wavelength	1310 nm
Optic received sensitivity	-34 dBm
Emitter electric level	$>$ -11 dBm;
Maximum transmission distance of optical fiber	2kM
Transmission rate for IEC61850	100Mbit/s
Transmission rate for DNP 3.0	100Mbit/s

Serial communication

Item	Data
Number	2
Port type	Extract twisted pair
Maximum transmission distance	1.0km
Voltage withstand test	500V earthing AC voltage
Transmission rate for IEC60870-5-103	Default setting 9600 bps; Minimum: 1200bps; maximum: 19200bps

Time synchronization

Item	Data
Synchronization mode	SNTP IRIG-B time sync Minute or second Pulse
IRIG-B signal format	IRIG-B000
IRIG-B Port type	Twisted-pair connection or optical fibers
IRIG-B signal voltage level	Differential signal input

Inter-substation communication

Item	Data
Ports number	2
Fiber optic cable type	Single-mode
Optic wavelength	1310 nm, when the transmission distance $<$ 60 km

Specification

	1550 nm, when the transmission distance >60 km	GB/T15145-2001 DL/T478-2013	◆ Input and output ports; ◆ Functional earth port; 1kV, at rated voltage≤60V, tested on: ◆ Communication port;
Optic received sensitivity	-34 dBm		
Emitter electric level	>-11 dBm, at length <40 km >-4 dBm, at length 40~60 km		
Fiber optic connector type	LC		
Data transmission rate	64 kbit/s, G703 2,048 kbit/s, G703-E1		
Max. transmission distance	120 km		

Product safety test

Item	Data
Over voltage category IEC60255-27	Category III
Pollution degree IEC60255-27	Degree 2
Insulation IEC60255-27	Basic insulation
Degree of protection (IP) IEC60255-27 IEC60529	Front plate: IP54 Side plate: IP52 Rear plate: IP30
Power frequency high voltage withstand test IEC60255-5 EN60255-5 ANSIC37.90 GB/T15145-2001 DL/T478-2013	2KV, 50Hz, at rated voltage > 63V, Tested on: ◆ Auxiliary power supply port; ◆ Enclosure port; ◆ Input and output ports; ◆ Functional earth port; 500V, 50Hz, at rated voltage ≤63V, Tested on: ◆ Communication port;
Impulse voltage IEC60255-5 IEC60255-27 EN60255-5 ANSIC37.90	5kV, at rated voltage>60V, Tested on: ◆ Auxiliary power supply port; ◆ Enclosure port;

Insulation resistance IEC60255-5 IEC60255-27 EN60255-5 ANSIC37.90 GB/T15145-2001 DL/T478-2013	≥100MΩ,500V, $\overline{\text{---}}$
Protective bonding resistance IEC60255-27	≤0.1Ω
Fire withstand/flammability IEC60255-27	Class V2

EMC test

Item	Data
Electrostatic discharge immunity test IEC60255-26:2013 IEC61000-4-2	Criteria A; Level IV; ±6kV contact discharge; ±8kV air gap discharge;
Radiated, radio-frequency electromagnetic field immunity test IEC60255-26:2013 IEC61000-4-3	Criteria A; Class IV; 10 V/m(r.m.s.), 80%,AM (1 kHz) Frequency sweep: 80 MHz – 1 GHz; 1.4 GHz – 2.7 GHz spot frequencies (MHz): 80; 160; 380; 450; 900; 1850; 2150.
Electrical fast transient/burst immunity test IEC60255-26:2013, IEC61000-4-4	Class A 4KV peak voltage; Tested on: ◆ Auxiliary power supply port;

Specification

ANSI/IEEE C37.90.1	<ul style="list-style-type: none"> ◆ Enclosure port; ◆ Input and output ports; ◆ Functional earth port; 2KV peak voltage; Tested on: <ul style="list-style-type: none"> ◆ Communication port; 	IEC61000-4-18 ANSI/IEEE C37.90.1	port; <ul style="list-style-type: none"> ◆ Input and output ports; 1 kV CM ; 0 kV DM; Tested on: <ul style="list-style-type: none"> ◆ Communication ports
Surge (impact) immunity test IEC60255-26:2013, IEC61000-4-5	Class A, Level IV 4.0kV, Line-to-earth; 2.0kV, Line-to-line; Tested on: <ul style="list-style-type: none"> ◆ Auxiliary power supply port; ◆ Enclosure port; ◆ Input and output ports; ◆ Functional earth port; 4.0kV, Line-to-earth; Tested on: <ul style="list-style-type: none"> ◆ Communication ports; 	Fast damped oscillatory wave immunity test IEC61000-4-18	Level 4 4 kV, at 3MHz, 10MHz, 30MHz. Tested on: <ul style="list-style-type: none"> ◆ Auxiliary power supply port; ◆ Input and output ports;
Test for Immunity to conducted disturbances, induced by radio-frequency fields IEC60255-26:2013 IEC61000-4-6	10 V/m(r.m.s.), 80%,AM (1 kHz) Frequency sweep: 150kHz–80MHz Spot frequencies: 27MHz and 68MHz; Tested on: <ul style="list-style-type: none"> ◆ Auxiliary power supply port; ◆ Input and output ports; ◆ Functional earth port; ◆ Communication ports; 	Pulse magnetic field immunity IEC61000-4-9	Class V 1000A/m
Power frequency magnetic field immunity test IEC60255-26: 2013 IEC61000-4-8	Class V 30A / m Continuous; 300A/m, from 1s to 3s; Test on: <ul style="list-style-type: none"> ◆ Enclosure ports; 	Damped oscillation magnetic field immunity test IEC61000-4-10	Class V 100A/m
Power frequency immunity test IEC60255-26:2013; IEC61000-4-16	Zone A 300V, CM; 150V, DM; Test on: <ul style="list-style-type: none"> ◆ Binary input ports; 	Conducted emission IEC60255-26:2013 CISPR22	Class A; 0.15MHz to 0.50MHz; 0.50MHz to 30MHz; Tested on: <ul style="list-style-type: none"> ◆ Auxiliary power supply port;
Slow damped oscillatory wave immunity test (1MHz) IEC60255-26:2013	Class III 2.5 kV CM ; 1 kV DM; Tested on: <ul style="list-style-type: none"> ◆ Auxiliary power supply 	Radiated emission IEC60255-26: 2013 CISPR11	Class A; 30MHz to 230MHz; 230MHz to 1GHz;
		DC voltage dips IEC60255-26:2013 IEC 61000-4-11 IEC 61000-4-29	20 ms at 0% residual voltage; 200 ms at 40% residual voltage; 500 ms at 70% residual voltage;
		AC voltage dips IEC60255-26:2013 IEC 61000-4-11 IEC 61000-4-29	At 60Hz: 1.0 cycle at 0% residual voltage; 12 cycle at 40% residual voltage,; 30 cycle at 70% residual voltage; At 50Hz: 1.0 cycle at 0% residual voltage;

Specification

	10 cycle at 40% residual voltage; 25 cycle at 70% residual voltage;	Contact insulation test (AC dielectric strength) IEC60255-1	AC1000V,1min
DC voltage interruptions IEC60255-26: 2013 IEC 61000-4-11 IEC 61000-4-29	5 s, at 0% residual voltage;	Maximum temperature that operation allows IEC60255-1	70°C
AC voltage interruptions IEC60255-26: 2013 IEC 61000-4-11 IEC 61000-4-29	At 60Hz: 300 cycle at 0% residual voltage; At 50Hz: 250 cycle at 0% residual voltage;		
A.C. component in d.c. (ripple) IEC60255-26:2013 IEC 61000-4-17	15%, at 100Hz, twice rated frequency; 15%, at 120Hz, twice rated frequency;		
Gradual shutdown/start-up (for d.c. power supply) IEC60255-26:2013	60 s shut down ramp 5 min power off 60 s start-up ramp		
DC voltage reverse polarity	1 min		

Contact performance test of power output relay

Item	Data
Mechanical endurance, Unloaded IEC60255-1	Unloaded, 10,000 times (switching frequency is 3Hz); Making, ≥1000; Breaking, ≥1000
Current carrying capacity IEC60255-1	10A continuous, 30A, 200ms on,15s off
Making capacity IEC60255-1	1250W(DC) at $V_{r,aux}$, L/R>40ms 2000VA(AC)
Breaking capacity IEC60255-1	0.25A, at $V_{r,aux}=220V$, L/R≤40ms; 0.45A, at $V_{r,aux}=110V$, L/R≤40ms; 1200VA, at $V_{r,AC}$;
Contact circuit resistance IEC60255-1	30mΩ
Contact insulation test (AC dielectric strength) IEC60255-1	AC1000V,1min
Maximum temperature that operation allows IEC60255-1	70°C

Contact performance test of general relay

Item	Data
Mechanical endurance, Unloaded IEC60255-1	Unloaded, 10,000 times (switching frequency is 3Hz); Making, ≥1000; Breaking, ≥1000
Current carrying capacity IEC60255-1	5A continuous, 30A, 200ms on,15s off
Making capacity IEC60255-1	1000W(DC) at $V_{r,aux}$, L/R>40ms 1000VA(AC)
Breaking capacity IEC60255-1	30W, at $V_{r,aux}$, L/R≤40ms; 1000VA, at $V_{r,AC}$;
Contact circuit resistance IEC60255-1	30mΩ

Mechanical test

Item	Data
Sinusoidal vibration response test IEC60255-21-1 EN60255-21-1	Class 1 10-60 Hz: ± 0.035 mm amplitude 60-150 Hz: 0,5g acceleration Frequency sweep: 1 octave/min

Specification

	1 sweep cycle in each axis Relay energized
Sinusoidal vibration endurance test IEC60255-21-1 EN60255-21-1	Class 1 10 Hz to 150 Hz: 1 g 20 sweep cycle in each axis Relay non-energized
Shock response test IEC60255-21-2 EN 60255-21-2	Class 1 Acceleration 5g, duration 11 ms. 3 shocks in each direction (6 shocks in each axis) Relay energized
Shock withstand test IEC60255-21-2 EN 60255-21-2	Class 1 Acceleration 15g, duration 11 ms. 3 shocks in each direction (6 shocks in each axis) Relay non-energized
Bump test IEC60255-21-2 EN 60255-21-2	Class 1 Acceleration 10g, duration 16 ms 1000 bumps in each direction (2000 bumps in each axis) Relay non-energized
Seismic test IEC60255-21-3	Class 1 1-8 Hz: ± 3.5 mm amplitude (horizontal axis) 1-8 Hz: ± 1.5 mm amplitude (vertical axis) 8-35 Hz: 1g acceleration (horizontal axis) 8-35 Hz: 0,5g acceleration (vertical axis) Frequency sweep 1 octave/min

	1 sweep cycle in each axis Relay energized
--	---

Environmental test

Item	Data
Cold test - Operation IEC60255-27 IEC60068-2-1	-40°C, 96 hours, rated load
Cold test – Storage IEC60255-27 IEC60068-2-1	-40°C, 96 hours
Dry heat test – Operation IEC60255-27 IEC60068-2-2	+75°C, 96 hours, rated load
Dry heat test – Storage IEC60255-27 IEC60068-2-2	+75°C, 96 hours
Change of temperature IEC60255-27 IEC60068-2-14	Test Nb, figure 2, 5 cycles -40°C / +70°C
Damp heat static test IEC60255-27 IEC60068-2-78	+40°C, 95% r.h. 56 days, rated load
Damp heat cyclic test IEC60255-27 IEC60068-2-30	+55°C, 97% r.h. 6 cycles, rated load

CE Certification

Item	Data
EMC	EN61000-6-2 and EN61000-6-4(EMC steering committee 2004/108/EC)
LVD	EN60255-27(LVD2006/95EC)

Connection

Typical connection 1

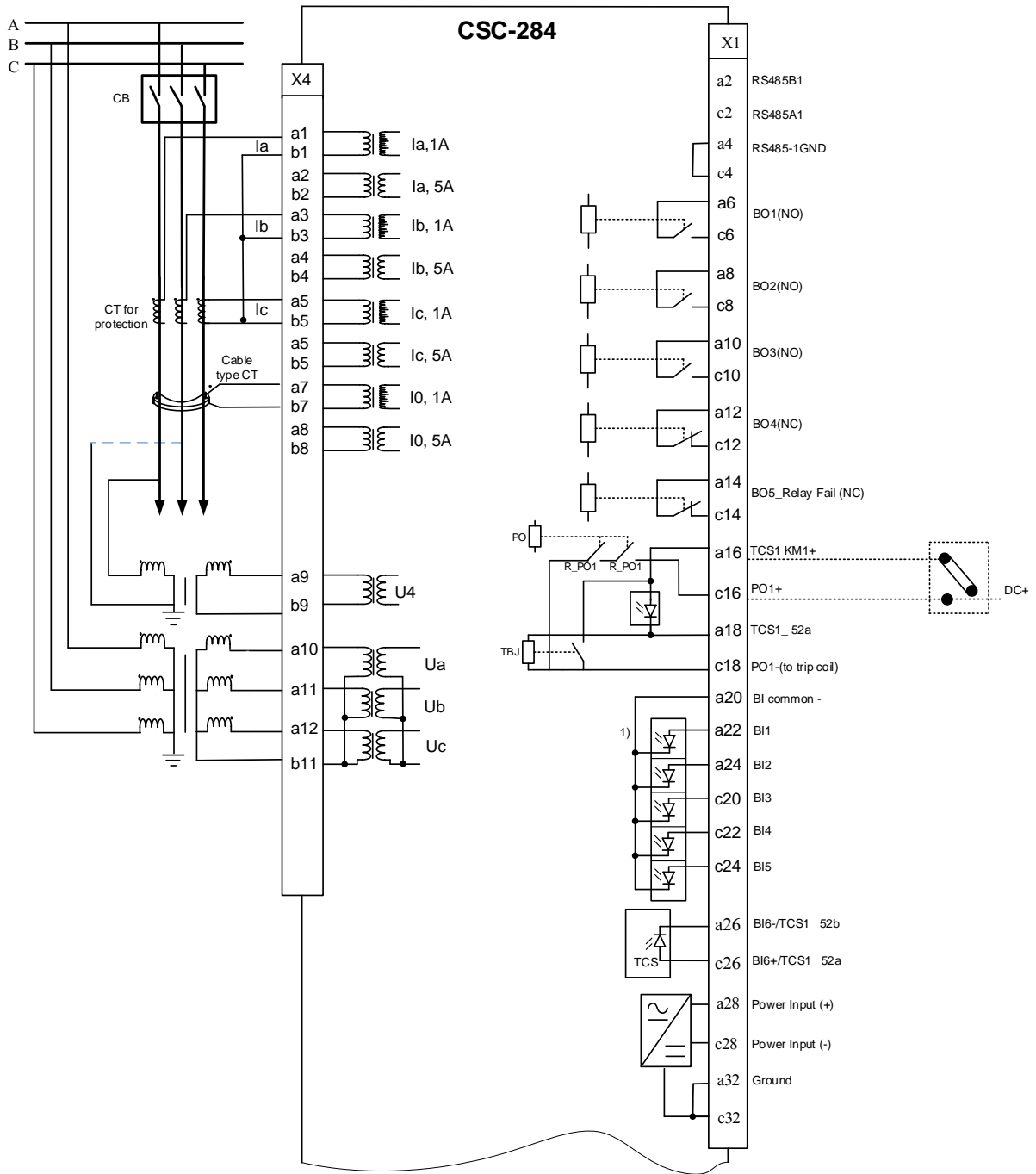

Connection

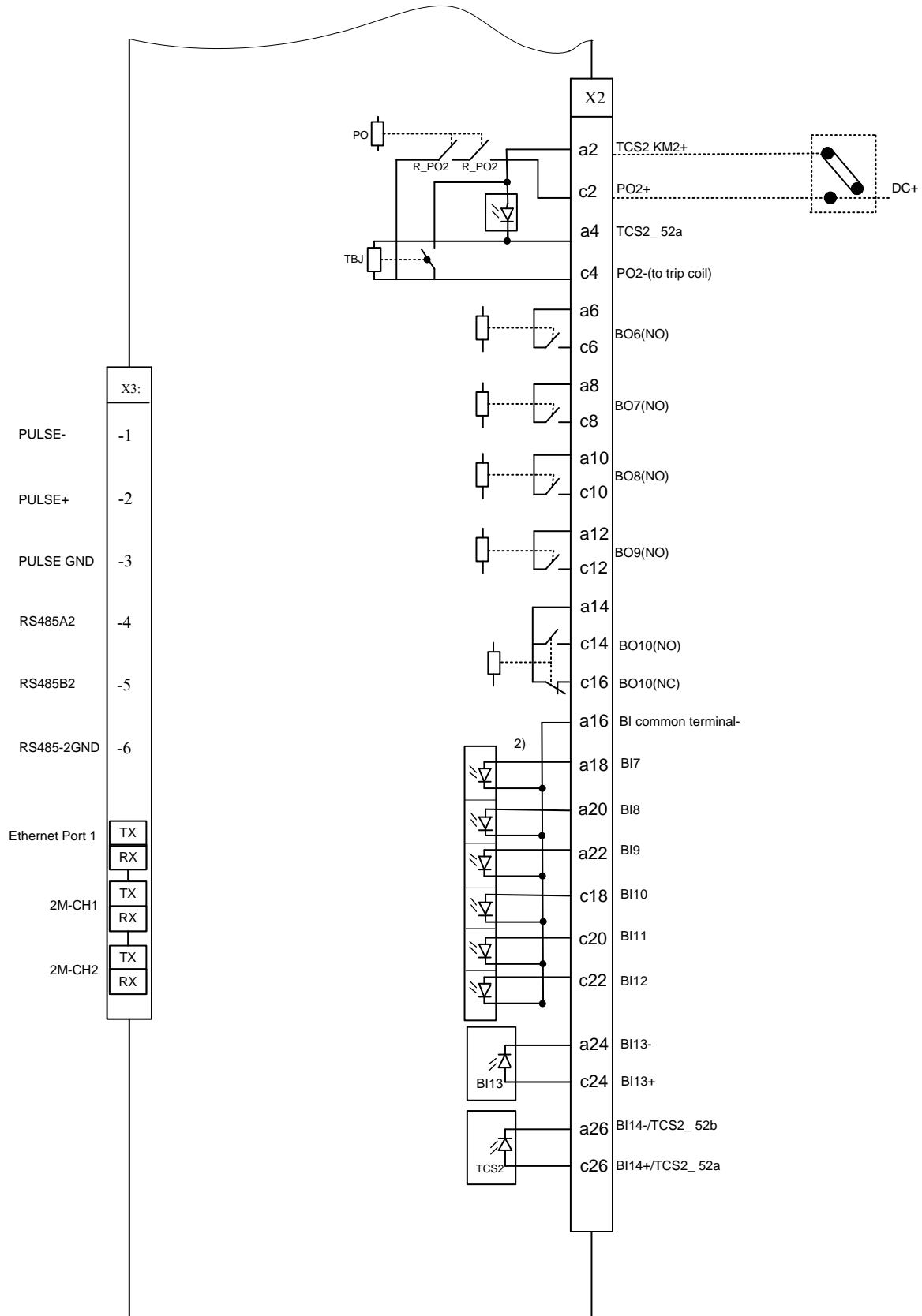

Connection

Typical connection 2, without VT

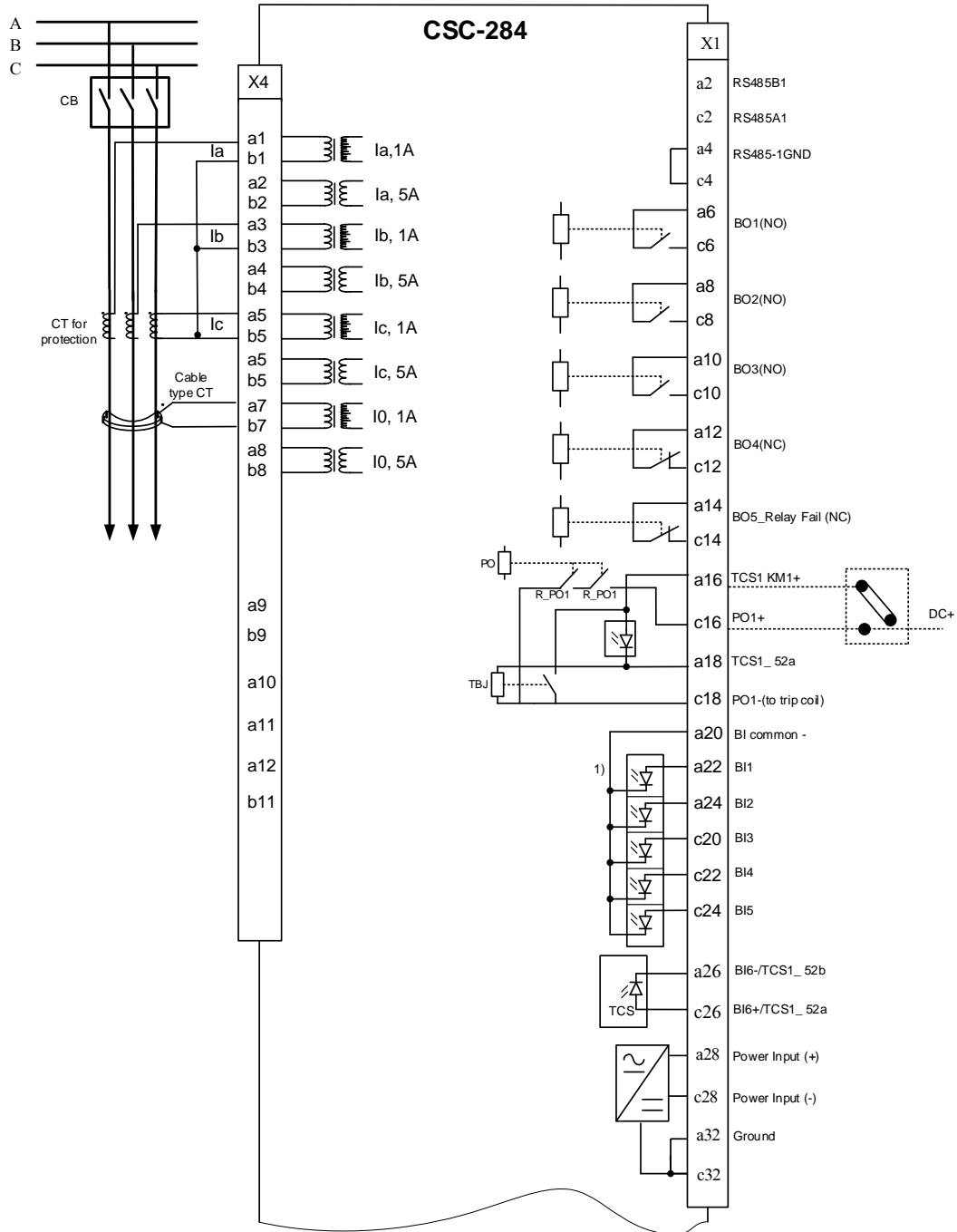

Connection

